

Overview

- The Remote Sensor (BA#-PP) is a small temperature conductive plastic sensor used for single point temperature measurement with twin plenum rated lead wires. It is ideal for mounting applications inside electronic circuit enclosures or existing thermostats.
- The Remote Probe with Plenum-Rated Cable (BA#-RPP) is a small Stainless Steel temperature sensor used for single point temperature measurement with PVC plenum rated cable. It is ideal for bracket mounting for Chamber, Duct, Thermowell or L-bracket applications.
- The Remote Probe with FEP-Jacketed Cable (BA#-RPFEP) is a small Stainless Steel temperature sensor used for single point temperature measurement with FEP plenum cable. It is ideal for bracket mounting in harsh environments for Chamber, Duct, Thermowell or L-bracket applications.
- The Remote Probe with FEP-Jacketed Cable for submersion (BA#-RPFEP2) is a small Stainless Steel temperature sensor used for single point temperature measurement with submersion FEP plenum cable. It is ideal for bracket mounting in wet or water submersion environments for Chamber, Duct, Immersion or L-bracket applications.

All of the above sensors are available in multiple types of thermistor's or RTD's as shown in the specifications. The probe is available bare without enclosure or using a termination enclosure in plastic or metal for NEMA1, NEMA 3R and NEMA 4 applications and are all plenum rated.

Identification

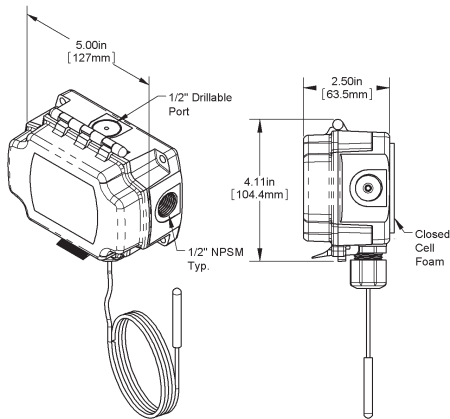
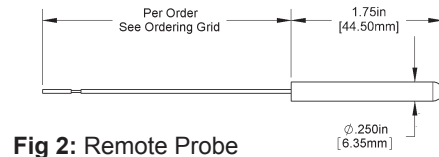
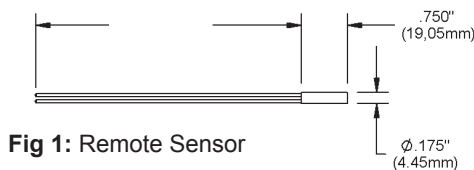

Fig 3: Remote Probe in a BAPI-Box (BB) Enclosure

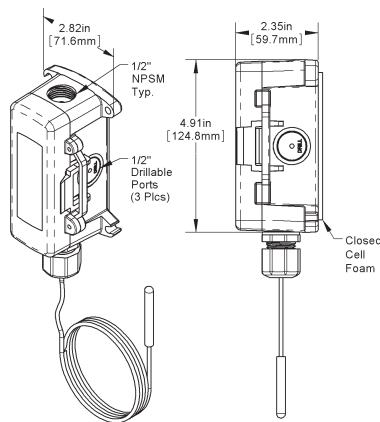

Fig 4: Remote Probe in a BAPI-Box 2 (BB2) Enclosure

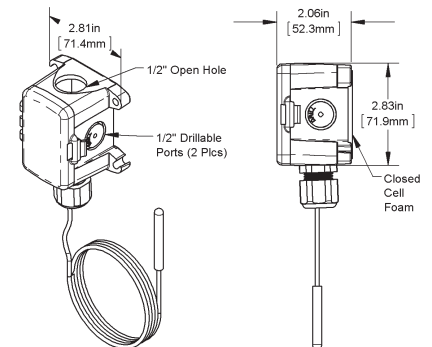

Fig 5: Remote Probe in a BAPI-Box 4 (BB4) Enclosure

(A Pierceable Knockout Plug is available from BAPI for the open port in the BB4. Part #BA/PAK-100)

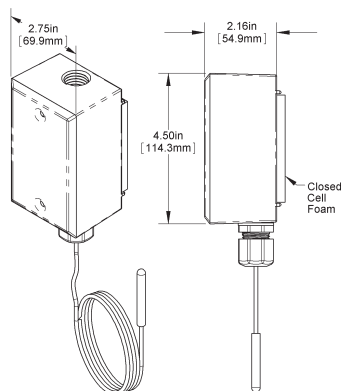

Fig 6: Remote Probe in a Weatherproof (WP) Enclosure

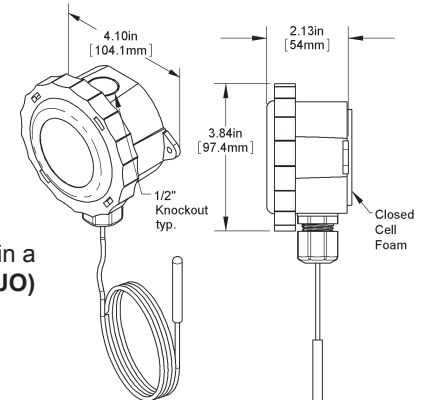
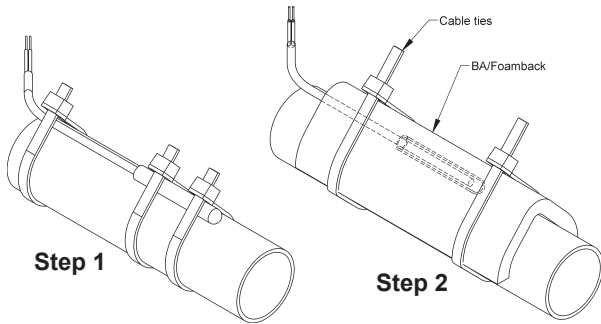

Fig 7: Remote Probe in a Weather Tight (EU, EUO) Enclosure

Specifications subject to change without notice.

Mounting



Step 1: Secure Sensor To Have Good Contact With Bare Pipe

Step 2: Insulate Over The Sensor (See Notes Below)

Notes: Insulation should be installed a minimum of 4 pipe diameters on each side of the strap-on sensor.

Example: 1/2" pipe x 4 = 2".

Insulation should be 2" on each side of the sensor wrapped all the way around the pipe.

Fig 8: Stainless Steel Remote Probes Strapped to Pipes

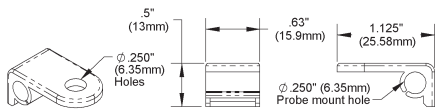

Fig 9A: Break-Off Tab from a BAPI Flexible Probe Bracket (BA/FPB)

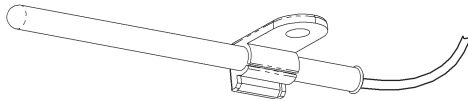

Fig 9B: Break-Off Tab Used to Mount a Stainless Steel Remote Probe.

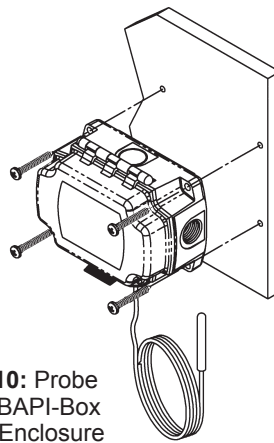

Fig 10: Probe with BAPI-Box (BB) Enclosure

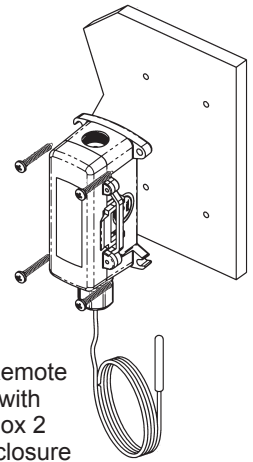

Fig 11: Remote Probe with BAPI-Box 2 (BB2) Enclosure

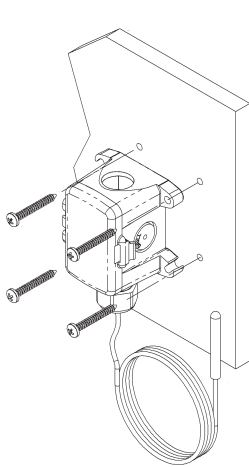

Fig 12: Remote Probe with BAPI-Box 4 (BB4) Enclosure

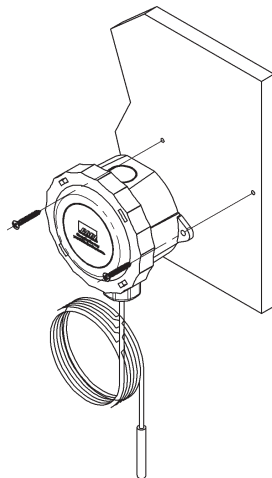

Fig 13: Remote Probe with Weather Tight (EU, EUO) Enclosure

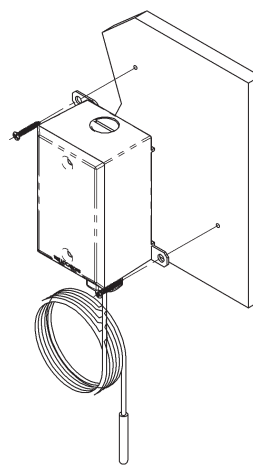

Fig 14: Remote Probe with Weatherproof (WP) Enclosure

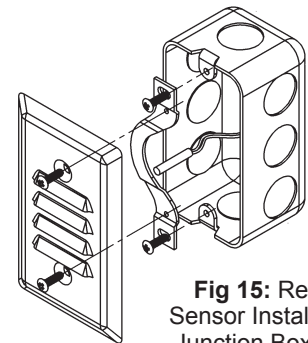

Fig 15: Remote Sensor Installed in a Junction Box with a Wall Plate Cover

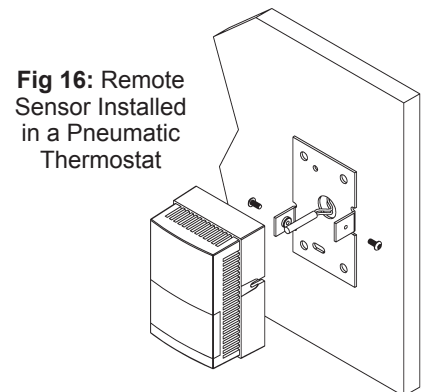

Fig 16: Remote Sensor Installed in a Pneumatic Thermostat

Specifications subject to change without notice.

Wiring & Termination

BAPI recommends using twisted pair of at least 22AWG and sealant filled connectors for all wire connections. Larger gauge wire may be required for long runs. All wiring must comply with the National Electric Code (NEC) and local codes.

Do NOT run this device's wiring in the same conduit as high or low voltage AC power wiring. BAPI's tests show that inaccurate signal levels are possible when AC power wiring is present in the same conduit as the sensor wires.

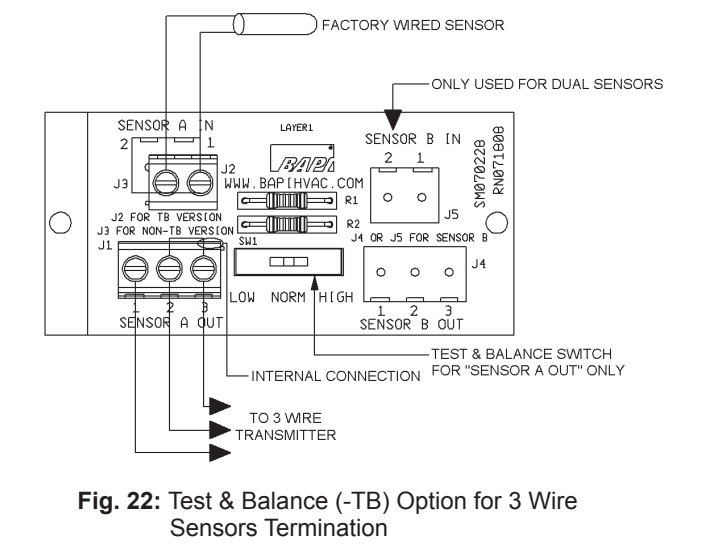
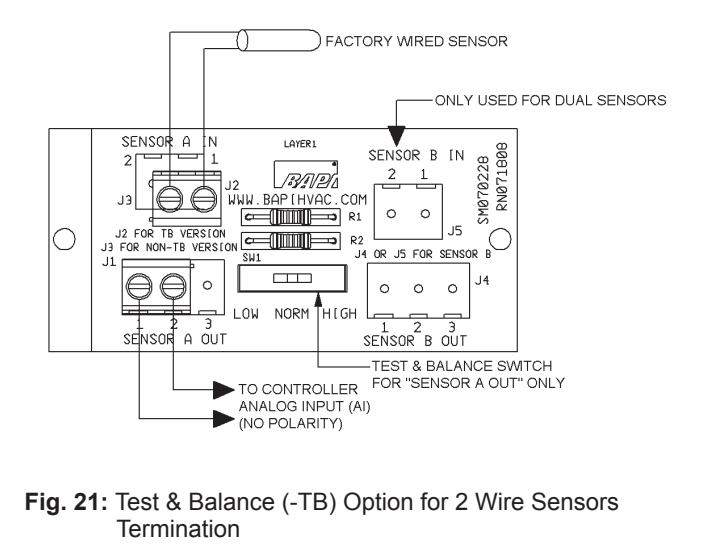
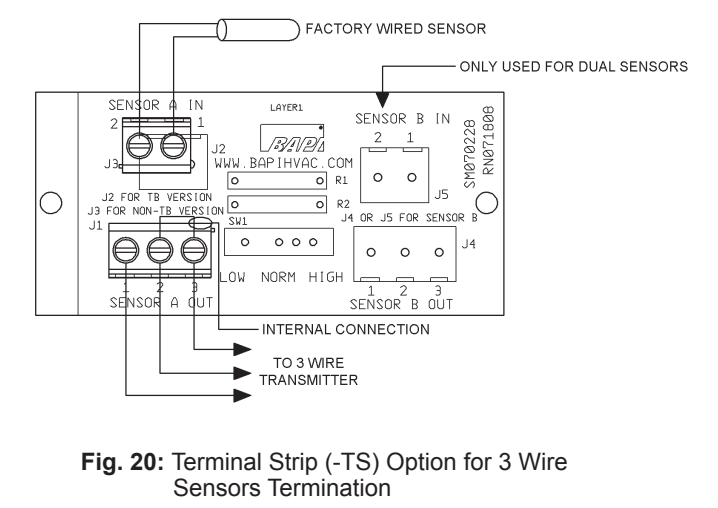
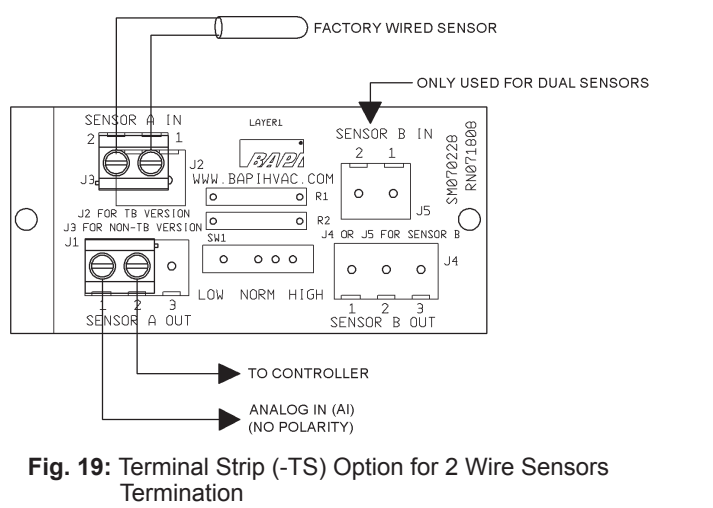
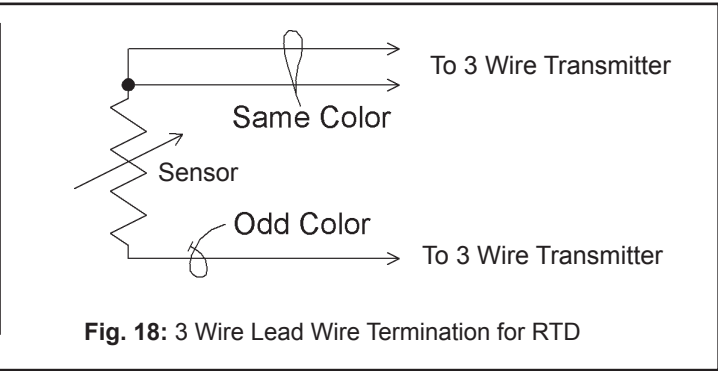
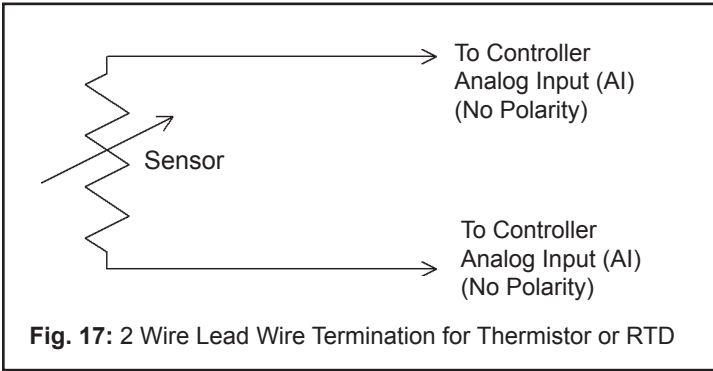



Diagnostics

Possible Problem:

Controller reports higher or lower than actual temperature

Possible Solutions:

- Confirm the input is set up correctly in the front end software
- Check wiring for proper termination & continuity. (shorted or open)
- Disconnect wires and measure sensor resistance and verify the "Sensor" output is correct.

Specifications

Sensor	Passive
Thermistor	NTC, 2 wire
RTD	PTC, 2 or 3 wire
Thermistor	Thermal resistor
Temp. Output	Resistance
Accuracy (Std)	±0.36°F, (±0.2°C)
Accuracy (High)	±0.18°F, (±0.1°C), [XP] option
Stability	< 0.036°F/Year, (<0.02°C/Year)
Heat dissipation	2.7 mW/°C
Temp. Drift	<0.02°C per year
Probe range	-40° to 221°F (-40° to 105°C)
RTD	Resistance Temperature Device
Platinum (Pt)	100Ω or 1KΩ @0°C, 385 curve,
Platinum (Pt)	1KΩ @0°C, 375 curve
Pt Accuracy (Std)	0.12% @Ref, or ±0.55°F, (±0.3°C)
Pt Accuracy (High)	0.06% @Ref, or ±0.277°F (±0.15°C), [A]option
Pt Stability	±0.25°F, (±0.14°C)
Pt Self Heating	0.4 °C/mW @0°C
Pt Probe range	-40° to 221°F, (-40 to 105°C)
Nickel (Ni)	1000Ω @70°F, JCI curve
Ni Probe range	-40° to 221°F (-40 to 105°C)
Sensitivity	Approximate @ 32°F (0°C)
Thermistor	Non-linier
	See bapivac.com "Sensor Specs"
1KΩ RTD (Pt)	3.85Ω/°C
100Ω RTD (Pt)	0.385Ω/°C
Nickel (Ni)	2.95Ω/°F for the JCI RTD
Lead wire	22awg stranded
Wire Insulation	
-PP	Etched Teflon leads, plenum rated
-RPP	Flame Retardant PVC plenum cable
-RPFEP	FEP jacketed plenum rated cable
-RPFEP2	FEP jacketed plenum and submersion rated cable
Probe	
-PP	Heat conductive plastic cup
-RPP, RPFEP	Rigid, 304 Stainless Steel, 0.25" OD

Probe Length	
-PP	0.875" (22.2mm)
-RPP, RPFEP	1.75" (44.5mm)
Mounting	External Probe Bracket required
Probe	Vented polycarbonate shield, ½" OD
Probe Length	1.2" with ½" NPT threads
Mounting	Extension tabs (ears), 3/16" holes
Enclosure Types:	(Part number designator in bold)
J-Box:	-JB , w/ eight ½" knock-outs
Weatherproof:	-WP , w/ two ½" FNPT entries, (Bell box)
BAPI-Box:	-BB , w/ four ½" NPSM & one ½" drill-out
BAPI-Box 2:	-BB2 , w/ three ½" NPSM & three ½" drill-outs
BAPI-Box 4:	-BB4 , w/ three ½" drill-outs & one ½" open port
Weather Tight:	-EU, EUO , w/ two ½" drill-outs
Enclosure Ratings:	(Part number designator in bold)
J-Box:	-JB , NEMA 1
Weatherproof:	-WP , NEMA 3R, IP14
BAPI-Box:	-BB , NEMA 4, IP66, UV Rated
BAPI-Box 2:	-BB2 , NEMA 4, IP66, UV Rated
BAPI-Box 4:	-BB4 , IP10 (IP44 with Knockout Plug in the open port)
Weather Tight:	-EU , NEMA 4, IP66
Weather Tight:	-EUO , NEMA 4, IP66, UV rated
Enclosure Material:	(Part number designator in bold)
J-Box:	-JB , Galvanized steel, UL94H-B
Weatherproof:	-WP , Cast Aluminum, UV rated
BAPI-Box:	-BB , Polycarbonate, UL94V-0, UV rated
BAPI-Box 2:	-BB2 , Polycarbonate, UL94V-0, UV rated
BAPI-Box 4:	-BB4 , Polycarbonate & Nylon, UL94V-0
Weather Tight:	-EU , ABS Plastic, UL94V-0
Weather Tight:	-EUO , Plastic, UL94V-0, UV rated
Ambient (Enclosure):	0 to 100% RH, Non-condensing
J-Box:	-JB , -40°F to 212°F, (-40° to 100°C)
Weatherproof:	-WP , -40°F to 212°F, (-40° to 100°C)
BAPI-Boxes:	-BB, BB2, BB4 -40 to 185°F, (-40 to 85°C)
Weather Tight:	-EU, EUO , -40°F to 185°F, (-40° to 85°C)
Agency:	RoHS, *CE PT= DIN43760, IEC Pub 751-1983, JIS C1604-1989 *Passive Thermistors 20KΩ and smaller are CE Compliant

Specifications subject to change without notice.